

Duct Sensor CO₂ / Humidity / Temperature

Duct air quality sensor for combined detection of CO₂, relative humidity and temperature. Designed for control and monitoring applications.

Type Overview

Type	Output Signal	Output signal active CO ₂	Output signal active temperature
22DTM-16	BACnet	DC 0...5 V, DC 0...10 V	DC 0...5 V, DC 0...10 V

Technical Data

Electrical data	Power Supply DC	15...24 V, ±10%, 0.3 W
	Power Supply AC	24 V, ±10%, 6 VA
	Electrical connection	Removable spring loaded terminal block max. 2.5 mm ²
	Cable entry	Cable gland M20 2 x Ø6 mm, with strain relief 2 x Ø6 mm
Functional data	Sensor Technology	NDIR (non dispersive infrared) with stainless steel wire mesh filter
	Communicative control	BACnet MS/TP (Details see separate document "Sensor BACnet PICS")
	Output signal active note	Output DC 0...5/10 V selectable with switch
	Media	Air
Measuring data	Measured values	CO ₂ Temperature Relative humidity
	Measuring range humidity	0...100% rH
	Measuring range temperature	0...50 °C [32...120 °F] selectable via BACnet Attention: max. measuring temperature is restricted by max. medium temperature (see Safety data)
	Accuracy CO ₂	±(50 ppm + 3% of measuring value)
	Accuracy humidity	±2% between 10...90% r.H. @ 21 °C
	Accuracy temperature active	±0.5 °C @ 21 °C [±0.9 °F @ 70 °F]
Materials	Operating condition air flow	min. 0.3 m/s max. 10 m/s
	Cable gland	PA6, black
	Housing	Cover: Lexan, Belimo orange NCS S0580-Y6OR Bottom: Lexan, Belimo orange NCS S0580-Y6OR Seal: 0467 NBR70, black
	Probe material	PA6, black

Safety data	Ambient humidity	85% r.H., non-condensing
	Ambient temperature	0...50 °C [32...120 °F]
	Medium temperature	0...50 °C [32...120 °F]
	Operating condition air flow	min. 0.3 m/s max. 10 m/s
	Protection class IEC/EN	III Protective extra-low voltage (PELV)
	Protection class UL	UL Class 2 Supply
	EU Conformity	CE Marking
	Certification IEC/EN	IEC/EN 60730-1 and IEC/EN 60730-2-9
	Certification UL	cULus acc. to UL60730-1A/-2-9/-2-13, CAN/ CSA E60730-1:02/-2-9, CE acc. to 2004/108/ EC and 2006/95/EC, NEMA 4X, IP65, UL Enclosure Type 4X
	Degree of protection IEC/EN	IP65
	Degree of protection NEMA/UL	NEMA 4X
	Quality Standard	ISO 9001
	Weight	0.27 kg

Safety notes

The installation and assembly of electrical equipment should only be performed by authorized personnel.

This device has been designed for use in stationary heating, ventilation and air conditioning systems and must not be used outside the specified field of application. Unauthorised modifications are prohibited. The product must not be used in relation with any equipment that in case of a failure may threaten human, animals or assets.

Ensure all power is disconnected before installing. Do not connect to live/operating equipment.

Please comply with

- Local laws, health & safety regulations, technical standards and regulations
- Condition of the device at the time of installation, to ensure safe installation
- This data sheet and installation manual

Remarks
Build-up of Self-Heating by Electrical Dissipative Power

Temperature sensors with electronic components always have a dissipative power which affects the temperature measurement of the ambient air. The dissipation in active temperature sensors shows a linear increase with rising operating voltage. This dissipative power should be taken into account when measuring temperature. In case of a fixed operating voltage (± 0.2 V) this is normally done by adding or reducing a constant offset value. As Belimo transducers work with a variable operating voltage, only one operating voltage can be taken into consideration, for reasons of production engineering. Transducers 0...10 V / 4...20 mA have a standard setting at an operating voltage of DC 24 V. That means, that at this voltage, the expected measuring error of the output signal will be the least. For other operating voltages, the offset error will be increased by a changing power loss of the sensor electronics. If a re-calibration should become necessary later directly on the sensor, this can be done by means of a trimming potentiometer on the sensor board.

Application Notice for Humidity Sensors

Refrain from touching the sensitive humidity sensor/element. Touching the sensitive surface will void warranty.

For standard environmental conditions the manufacturing accuracy specified in the datasheet will be covered by the calibration warranty for two years. When exposed to harsh environmental conditions such as; high ambient temperature and/or high levels of humidity or presence of aggressive gases (i.e. chlorine, ozone, ammonia) the sensor element may be affected and readings may be outside specified accuracy. Replacement of deteriorated humidity sensor due to harsh environmental conditions are not subject of the general warranty.

Information Self-Calibration Feature CO₂

All CO₂ sensors are subject to drift caused by the aging process of the components, resulting in regular re-calibration or replacement units. However the dual channel technology integrates automatic self-calibration technology vs common used ABC-Logic sensors. Dual channel self-calibration technology is ideally suited for applications operating 24/7 hours such as hospitals or other commercial applications. Manual calibration is not required.

Accessories
Scope of delivery

Mounting flange
Strain relief $\varnothing 6...8$ mm
Cable Gland Nut PG11, $\varnothing 6...10$ mm

Optional accessories
Description
Type

Replacement filter Stainless steel, wire mesh

A-22D-A06

Wiring diagram

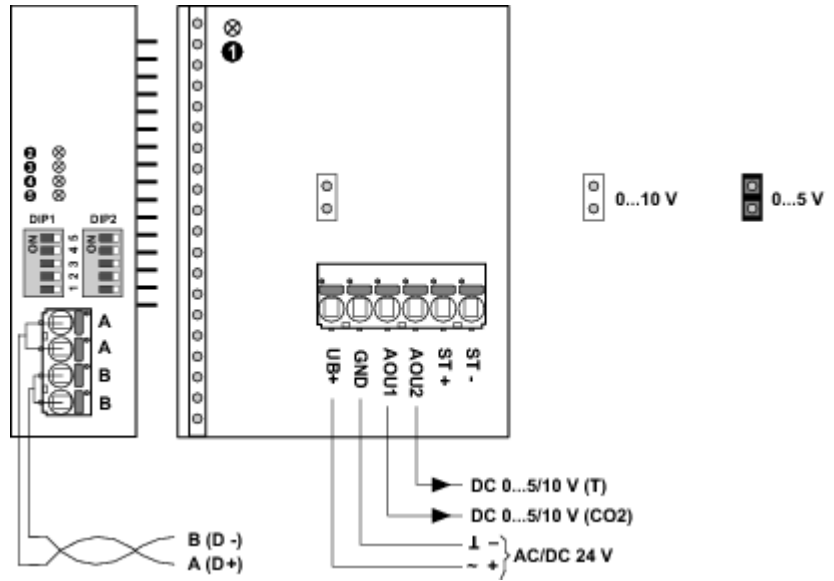

- ① and ⑤: Status LED
- ② red: Error
- ③ yellow: Tx
- ④ yellow: Rx

Detailed documentation

The separate document, BACnet PICS, informs about the PICS, MAC addressing and bus Termination (DIP1 & DIP2).

Notes Wiring RS485

Connection via safety isolating transformer.



Parallel connection of other devices possible. Observe the performance data.

The wiring of the line for BACnet MS/TP / Modbus RTU is to be carried out in accordance with applicable RS485 regulations.

Modbus / BACnet: Supply and communication are not galvanically isolated. Connect earth signal of the devices with one another.

Wiring RS485 (Modbus RTU & BACnet MS/TP)

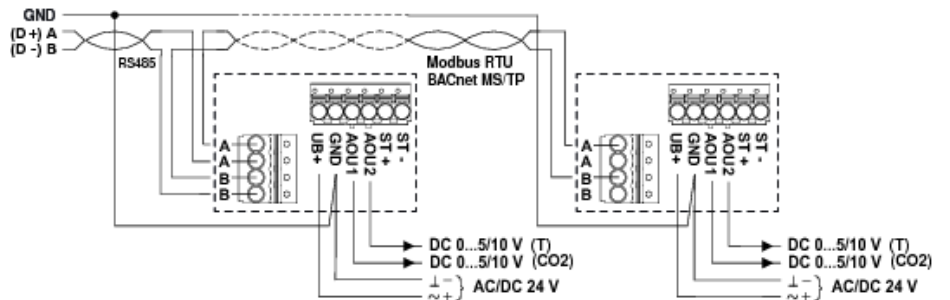

Dimensions

